



# RM 6000 RMD 6000 SERIES

## Specifications

Narrow-Aisle Reach Truck



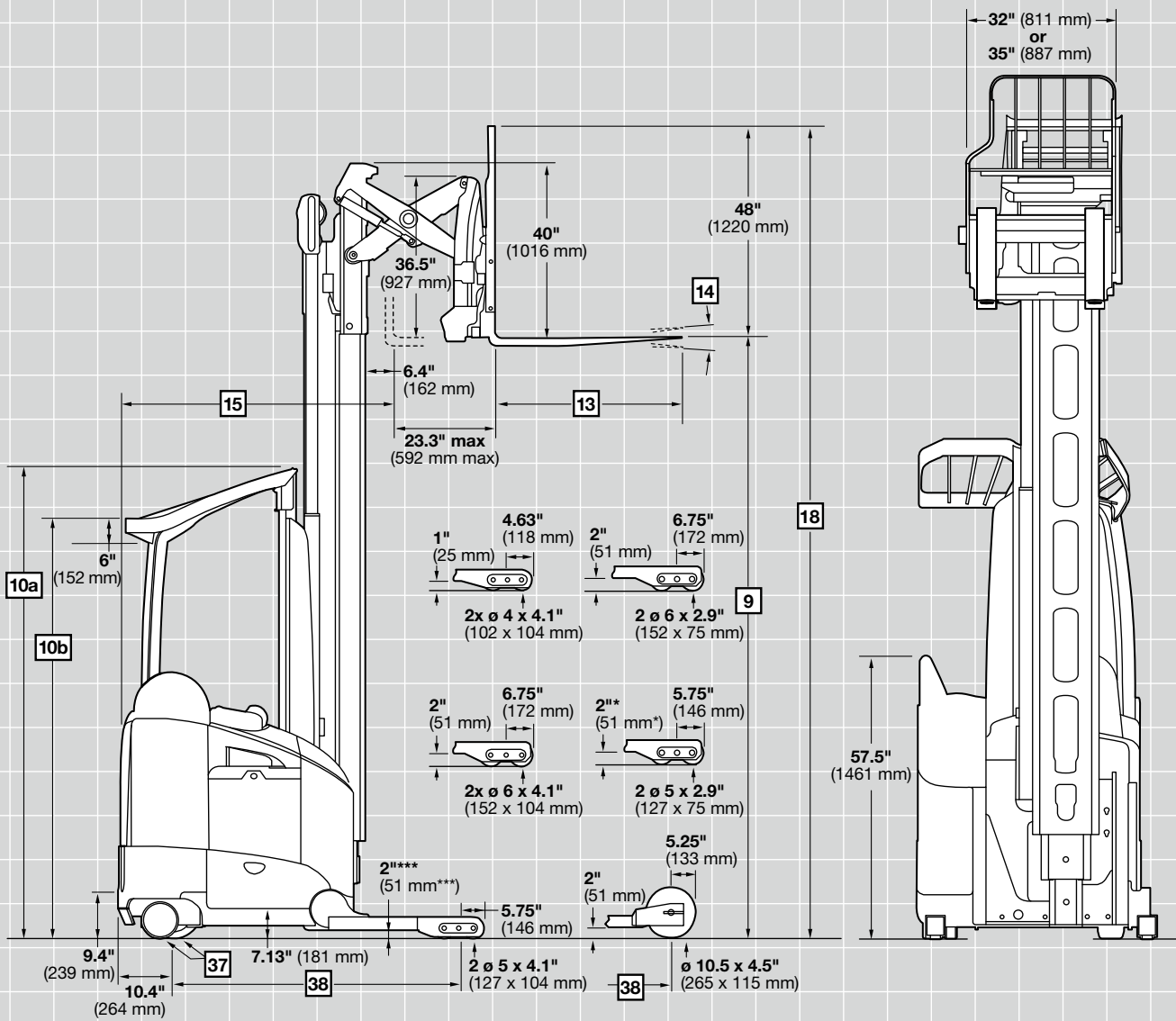
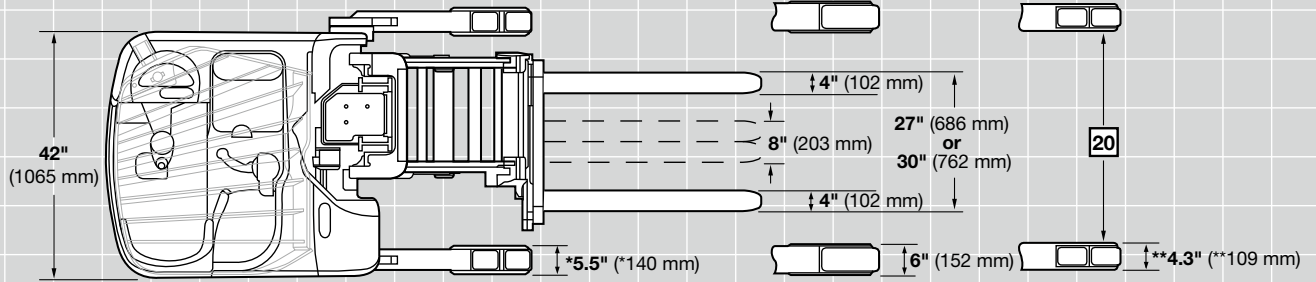

\* 5.86" (149 mm) with QuickChange Load Wheels.

\*\* 4.6" (117 mm) with QuickChange Load Wheels.

\*\*\*1" (25 mm) on lift heights above 321" (8155 mm).

**RM 6000 Series**

**Specifications**

<b>General Information</b>	1	<b>Manufacturer</b>		<b>Crown Equipment Corporation</b>			
	2	<b>Model</b>		<b>RM 6025</b>			
	3	<b>Load Capacity*</b>	Max	lb	kg	4500	2000
	4	<b>Load Center</b>	Fork Face to Load CG	in	mm	24	600
	5	<b>Power</b>		36 Volts			
	6	<b>Operator Type</b>	Reach	Stand			
	7	<b>Tire Type</b>	Load/Caster/Drive	Poly / Poly / Poly			
	8	<b>Wheels (x = driven)</b>	Load/Power Unit	4 / 2 (1x)			
<b>Dimensions</b>		<b>Mast Type</b>	High Visibility	MM			
	9	<b>Lift Height</b>		in	mm	See Mast Chart Below	
	10	<b>Guard Height</b>		in	mm	See Mast Chart Below	
	13	<b>Forks</b>	Standard L x W x T	in	mm	36 x 4 x 1.75	914 x 102 x 45
			Optional Lengths	in	mm	30, 39, 42, 45, 48	762, 990, 1065, 1145, 1220
	14	<b>Carriage</b>	Tilt F°/B°	degree	3/4		
	15	<b>Headlength**</b>	Compartment "C"	in	mm	56.00	1423
			Compartment "D"	in	mm	57.80	1467
			Compartment "E"	in	mm	60.40	1534
	17	<b>Overall Collapsed Height</b>		in	mm	See Mast Chart Below	
18	<b>Overall Extended Height</b>		in	mm	See Mast Chart Below		
20	<b>Inside Straddle Width***</b>	In 1" (25 mm) increments	in	mm	34 - 50	865 - 1270	
<b>Performance</b>	24	<b>Speed Travel</b>	Power Unit First (E/L)	mph	km/h	8.0 / 7.2	13.0 / 11.6
			Forks First (E/L)	mph	km/h	6.8 / 5.7	11.0 / 9.2
	25	<b>Speed Lift - AC †</b>	Empty	fpm	mm/s	160	813
			1000 lb (454 kg)	fpm	mm/s	139	706
			2000 lb (907 kg)	fpm	mm/s	121	615
			3000 lb (1361 kg)	fpm	mm/s	105	533
			3500 lb (1586 kg)	fpm	mm/s	98	498
			4000 lb (1815 kg)	fpm	mm/s	96	488
			4500 lb (2000 kg)	fpm	mm/s	95	483
	26	<b>Speed Lower</b>	Empty/Loaded	fpm	mm/s	110 / 110	559 / 559
26a	<b>Speed Xpress™ Lower</b>	Empty/Loaded	fpm	mm/s	110 - 240 / 110 - 240 ††	559 - 1219 / 559 - 1219 ††	
37	<b>Tires</b>	Size - Drive/Caster	in	mm	13 x 5.5 / 8 x 4	330 x 140 / 203 x 102	
<b>Chassis</b>	38	<b>Wheelbase (Standard Wheel)</b>	Compartment "C"	in	mm	60.51	1537
			Compartment "D"	in	mm	62.28	1582
			Compartment "E"	in	mm	64.88	1648
	39	<b>Suspension</b>	Drive	Articulated			
			Caster	Articulated, Swivel			
	42	<b>Brakes</b>	Drive	Elec Release / Mech Applied			
Caster			None				
Parking			Elec Release / Mech Applied				

\* Contact factory. Capacity may be subject to derating at height.  
 \*\* Sideshift included.  
 \*\*\* Inside straddle is decreased .35" (9 mm) with Quick Change Load Wheels.  
 † Maximum lift speeds with the maximum available battery compartment.  
 †† Average speed is 205 fpm (1041 mm/s).

<b>Mast Chart</b>			<b>TT - RM 6025</b>																			
<b>Mast</b>	<b>9</b>	Lift Height	in	mm	192	4875	210	5335	240	6095	270	6860	300	7620	321	8155	341	8660	366	9295	400	10160
		Free Lift*	in	mm	27	685	39	990	59	1495	71	1800	83	2105	92	2335	101	2565	112	2845	124	3150
	<b>10a</b>	Guard Height- Top Front	in	mm	89	2261	95	2413	107	2718	107	2718	107	2718	107	2718	107	2718	107	2718	107	2718
	<b>10b</b>	Guard Height- Top Back	in	mm	89	2261	95	2413	95	2413	95	2413	95	2413	95	2413	95	2413	95	2413	95	2413
	<b>11a</b>	Flat Guard Height- Top	in	mm	89	2261	95	2413	95	2413	95	2413	95	2413	95	2413	95	2413	95	2413	95	2413
	<b>11b</b>	Post Transition	in	mm	80	2032	86	2184	86	2184	86	2184	86	2184	86	2184	86	2184	86	2184	86	2184
	<b>17</b>	Overall Collapsed Height	in	mm	89	2260	95	2415	107	2720	119	3025	131	3325	140	3555	149	3785	160	4065	172	4370
	<b>18</b>	Overall Extended Height*	in	mm	240	6100	258	6555	288	7315	318	8080	348	8840	369	9375	389	9880	414	10515	448	11380
			Minimum Straddle OD	in	mm	42	1067	42	1067	42	1067	42	1067	42	1067	42	1067	42	1067	45	1143	48
<b>Weight</b>	Truck Weight w/o Battery		<b>RM 6025</b>																			
	Battery Compartment	"C" lb kg	6323	2868	6442	2922	6610	2998	6918	3138	7179	3256	7463	3385	na	na	na	na	na	na	na	na
		"D" lb kg	6372	2890	6491	2944	6658	3020	6967	3160	7227	3278	7512	3407	7653	3471	na	na	na	na	na	na
		"E" lb kg	6411	2908	6530	2962	6698	3038	7007	3178	7267	3296	7553	3426	7692	3489	7944	3603	8155	3699		

\* With load backrest 48" (1220 mm).  
 Note: Above 321" (8155 mm), 6" (152 mm) high load wheel standard.

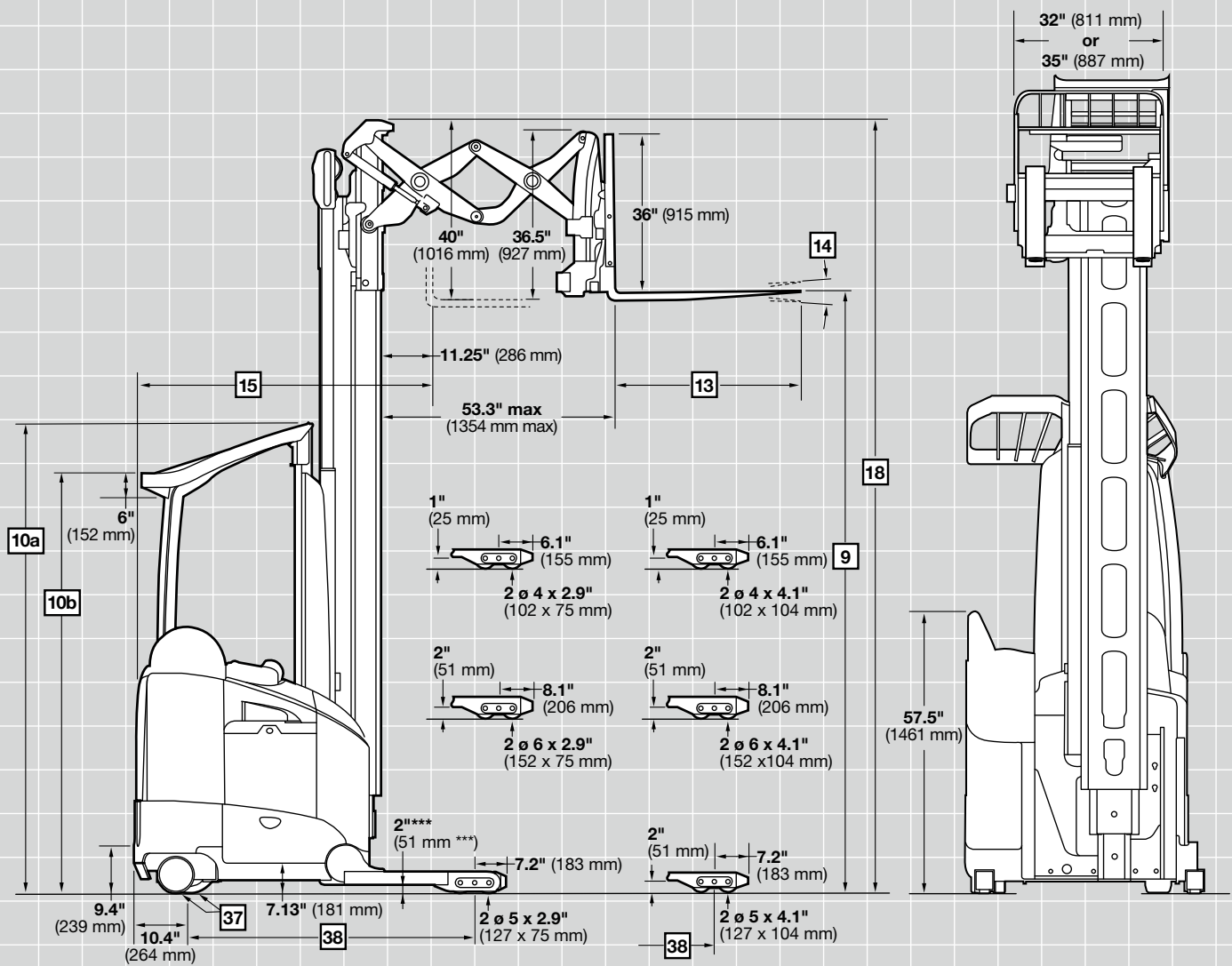
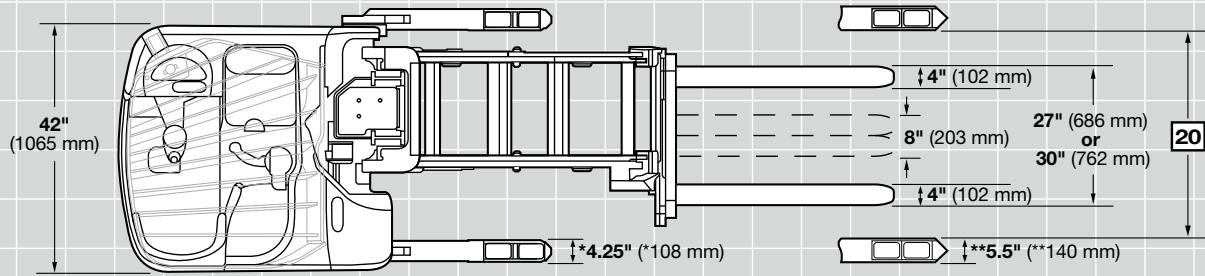

\*4.6" (\*\*117 mm) with QuickChange Load Wheels.  
 \*\*5.86" (\*\*149 mm) with QuickChange Load Wheels.  
 \*\*\*1" (\*\*25 mm) on lift heights above 321" (8155 mm).

**RMD 6000 Series**

**Specifications**

<b>General Information</b>	1	<b>Manufacturer</b>		<b>Crown Equipment Corporation</b>			
	2	<b>Model</b>		<b>RMD 6025</b>			
	3	<b>Load Capacity*</b>	Max	lb	kg	3200	1450
	4	<b>Load Center</b>	Fork Face to Load CG	in	mm	24	600
	5	<b>Power</b>		36 Volts			
	6	<b>Operator Type</b>	Reach	Stand			
	7	<b>Tire Type</b>	Load/Caster/Drive	Poly / Poly / Poly			
	8	<b>Wheels (x = driven)</b>	Load/Power Unit	4 / 2 (1x)			
	<b>Mast Type</b>	High Visibility	MM				
<b>Dimensions</b>	9	<b>Lift Height</b>		in	mm	See Mast Chart Below	
	10	<b>Guard Height</b>		in	mm	See Mast Chart Below	
	13	<b>Forks</b>	Standard L x W x T	in	mm	36 x 4 x 1.75	914 x 102 x 45
			Optional Lengths	in	mm	30, 39, 42, 45, 48	762, 990, 1065, 1145, 1220
	14	<b>Carriage</b>	Tilt F°/B°	degree	3/4		
	15	<b>Headlength**</b>	Compartment "C"	in	mm	60.90	1547
			Compartment "D"	in	mm	62.60	1591
			Compartment "E"	in	mm	65.30	1658
17	<b>Overall Collapsed Height</b>		in	mm	See Mast Chart Below		
18	<b>Overall Extended Height</b>		in	mm	See Mast Chart Below		
20	<b>Inside Straddle Width***</b>	In 1" (25 mm) increments	in	mm	34 - 50	865 - 1270	
<b>Performance</b>	24	<b>Speed Travel</b>	Power Unit First (E/L)	mph	km/h	8.0 / 7.2	13.0 / 11.6
			Forks First (E/L)	mph	km/h	6.8 / 5.7	11.0 / 9.2
	25	<b>Speed Lift - AC †</b>	Empty	fpm	mm/s	160	813
			1000 lb (454 kg)	fpm	mm/s	139	706
			2000 lb (907 kg)	fpm	mm/s	121	615
			3000 lb (1361 kg)	fpm	mm/s	105	533
26	<b>Speed Lower</b>	Empty/Loaded	fpm	mm/s	110 / 110	559 / 559	
26a	<b>Speed Xpress™ Lower</b>	Empty/Loaded	fpm	mm/s	110 - 240 / 110 - 240 ††	559 - 1219 / 559 - 1219 ††	
37	<b>Tires</b>	Size - Drive/Caster	in	mm	13 x 5.5 / 8 x 4	330 x 140 / 203 x 102	
<b>Chassis</b>	38	<b>Wheelbase (Standard Wheel)</b>	Compartment "C"	in	mm	60.51	1537
			Compartment "D"	in	mm	62.28	1582
			Compartment "E"	in	mm	64.88	1648
	39	<b>Suspension</b>	Drive	Articulated			
			Caster	Articulated, Swivel			
	42	<b>Brakes</b>	Drive	Elec Release / Mech Applied			
Caster			None				
Parking			Elec Release / Mech Applied				

\* Contact factory. Capacity may be subject to derating at height.

\*\* Sideshift included.

\*\*\* Inside straddle is decreased by .35" (9 mm) with Quick Change Load Wheels.

† Maximum lift speeds with the maximum available battery compartment.

†† Average speed is 205 fpm (1041 mm/s).

<b>Mast Chart</b>			<b>TT - RMD 6025</b>																					
<b>Mast</b>	<b>9</b>	Lift Height	in	mm	192	4875	210	5335	240	6095	270	6860	300	7620	321	8155	341	8660	366	9295	400	10160		
		Free Lift*	in	mm	27	685	39	990	63	1600	75	1905	87	2210	96	2438	105	2667	116	2946	128	3251		
	<b>10a</b>	Guard Height- Top Front	in	mm	89	2261	95	2413	107	2718	107	2718	107	2718	107	2718	107	2718	107	2718	107	2718	107	2718
	<b>10b</b>	Guard Height- Top Back	in	mm	89	2261	95	2413	95	2413	95	2413	95	2413	95	2413	95	2413	95	2413	95	2413	95	2413
	<b>11a</b>	Flat Guard Height- Top	in	mm	89	2261	95	2413	95	2413	95	2413	95	2413	95	2413	95	2413	95	2413	95	2413	95	2413
	<b>11b</b>	Post Transition	in	mm	80	2032	86	2184	86	2184	86	2184	86	2184	86	2184	86	2184	86	2184	86	2184	86	2184
	<b>17</b>	Overall Collapsed Height	in	mm	89	2260	95	2415	107	2720	119	3025	131	3325	140	3555	149	3785	160	4065	172	4370		
	<b>18</b>	Overall Extended Height*	in	mm	234	5945	250	6350	280	7115	310	7875	340	8640	361	9170	381	9680	406	10315	440	11180		
	Minimum Straddle OD	in	mm	42	1067	42	1067	42	1067	42	1067	42	1067	42	1067	42	1067	42	1067	45	1143	48	1219	
<b>Weight</b>	Truck Weight w/o Battery			<b>RMD 6025</b>																				
		"C"	lb	kg	6508	2952	6627	3006	6795	3082	7104	3222	7364	3340	7650	3470	na	na	na	na	na	na		
		"D"	lb	kg	6559	2975	6678	3029	6844	3104	7154	3245	7412	3362	7699	3492	7838	3555	na	na	na	na		
		"E"	lb	kg	6599	2993	6718	3047	6885	3123	7194	3263	7454	3381	7739	3510	7878	3573	8129	3687	8343	3784		

\* To reach carriage with load backrest 36" (915 mm).

Note: Above 321" (8155 mm), 6" (152 mm) high load wheel standard.

# RM 6000 Series RMD 6000 Series

## Specifications

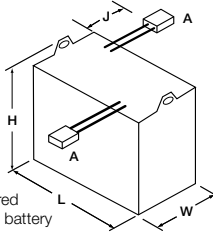
<b>Battery</b>	<b>Battery Removal</b>	Both Sides			
	45 <b>Type</b>	Lead Acid			
	46	<b>Min Weight/Max Amp-hrs</b>			
	 <p>* Width is measured on the side of the battery with lifting hooks</p>	"C" Battery Compartment- Up to 321" (8155 mm)	lb/Ah kg/Ah	2000 / 930	907 / 930
		"D" Battery Compartment- Up to 341" (8660 mm)	lb/Ah kg/Ah	2280 / 1085	1034 / 1085
		"E" Battery Compartment - ≤ 400" (10160 mm)	lb/Ah kg/Ah	2600 / 1240	1179 / 1240
		<b>Max Battery Size</b>	L x W x H		
	"C" Battery Compartment	in mm	38.38 x 16.25 x 31	975 x 413 x 787	
	"D" Battery Compartment	in mm	38.69 x 18.00 x 31	983 x 457 x 787	
	"E" Battery Compartment	in mm	38.69 x 20.75 x 31	983 x 527 x 787	
<b>Connector Location / Length (J)</b>	A / 9"		A / 229 mm		
<b>Standard Connector</b>	SB350 Gray				

# RM 6000 Series RMD 6000 Series

## Drive-in Rack Third Post and Flat OHG Options

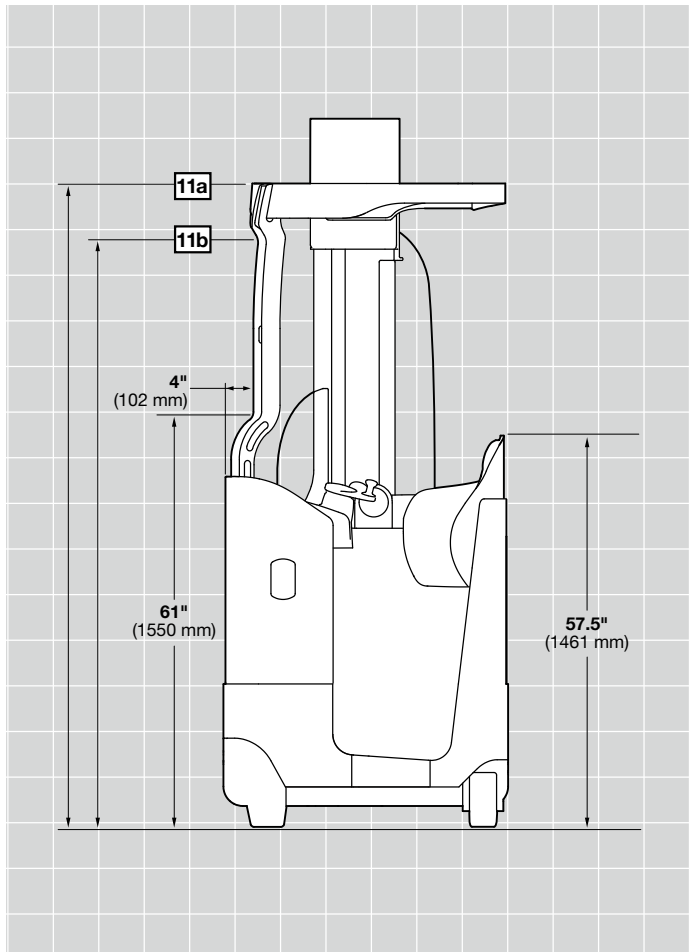

**Note: Power unit is not centered on the outriggers.** In drive-in rack applications, the power unit will sit closer to the support rails on the operator side of the truck. Please use caution when specifying.

The outriggers will be offset 1.5" (38 mm) to the left on all outrigger configurations except 42" (1067 mm), 43" (1092 mm) and 44" (1118 mm) OD. These will be offset .25" (6 mm) to the left. See Example Below:

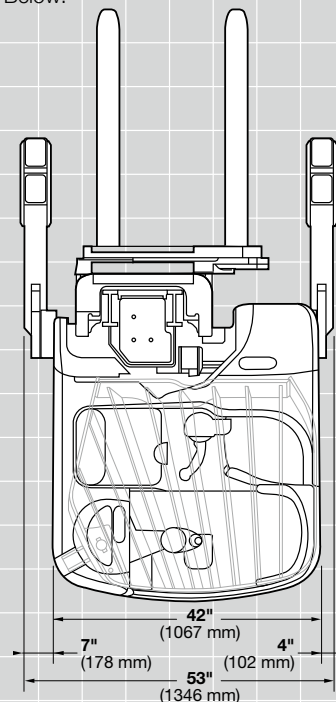

*Dimensions shown are an example only and are not applicable for all configurations.*

## RM 6000 Series RMD 6000 Series

## Technical Information

### Capacity

Model RM 6025: 4500 lb (2000 kg) at 24" (600 mm) load center, 36 volt

Model RMD 6025: 3200 lb (1450 kg) at 24" (600 mm) load center, 36 volt

### Batteries

Battery removal from left or right side of truck. Standard battery compartment rollers for extraction with mechanized equipment.

### Standard Equipment

1. MonoLift® mast
2. Crown's Access 1 2 3® Comprehensive System Control
3. 36 volt system
4. AC Traction System
5. AC Hydraulics with electronic power steering
6. Regenerative Lowering
7. OnTrac® Anti-Slip Traction Control
8. Operator Compartment
  - Variable side stance
  - Flexible five-point positioning
  - Back support with integral hip support
  - Arm/elbow support padding
  - Padded compartment interior walls
  - Operator console with work surface and storage
  - Entry bar
  - Suspended floor
  - 270 in<sup>2</sup> (1742 cm<sup>2</sup>) floor area
  - Premium urethane floorboard cushion
  - Work Assist® Mirror
9. Multi-task control handle
10. Crown display
  - Event code display with five (5) key navigation
  - Hour meters / travel distance / stop watch
  - PIN Code access capable
  - Access 1 2 3 diagnostics
  - P1, P2, P3 performance tuning
  - Battery discharge indicator, steer wheel direction indicator, OnTrac® Traction Control indicator
11. High visibility power unit
12. Angled overhead guard
13. Polycarbonate mast guard
14. Integrated sideshift RM-2" (51 mm) or 4" (102 mm), RMD-2" (51 mm)

15. Load backrest—RM-48" (1220 mm), RMD-36" (915 mm)
16. Tilting fork carriage
17. Tandem articulating load wheels
18. Lift slow down 12" (305 mm) from maximum lift height
19. Lift Limit without override
20. Chain slack detection
21. Crown-manufactured drive and lift motors
22. Offset articulated drive axle with 190° steer arc
23. Horn
24. Emergency power disconnect
25. 350 amp battery connector
26. Large diameter battery rollers
27. Color-coded wiring
28. Third post
29. Forward steering
30. InfoPoint® System with Quick Reference Guide
31. Static Strap
32. Work Assist® Accessory Tube

### Optional Equipment

1. Xpress™ Lower
2. Rack Height Select and Tilt Position Assist
3. Capacity monitor
4. Camera and color monitor (Must be Collapsed Height ≥ 26" (660 mm) above Overhead Guard)
5. Laser Fork Guide
6. Lift limit with override
7. Zone Select Key switch
8. Quick Change bolt-on outrigger tips
9. Bolt-on outrigger tips
10. Mesh screen mast guard
11. Battery retainer with interlock
12. 5th battery compartment roller
13. Load backrest RM- 36" (915 mm) and 42" (1067 mm) RMD- 42" (1067mm) and 48" (1220 mm)
14. Overhead guard mesh
15. Flat overhead guard
16. Plastic lens Work Assist® Mirror
17. Polished and tapered forks
18. Fork lengths
19. Heavy-duty skirt
20. Work light
21. Plastic LED work light
22. LED flashing light
23. Console area light
24. Travel alarm

25. Keyless on/off switch
26. Corrosion/freezer conditioning (freezer conditioning includes a 5/8" (16 mm) thick power unit skirt with extended coverage of the drive and caster tires)
27. ThermoAssist™ freezer comfort package
28. UL EE Rating
29. Load wheel sizes and compounds
30. Drive tire compounds
31. Reverse Steering
32. Short steer tiller
33. Maintenance platform
34. Remote raise/lower
35. Work Assist® Accessories:
  - Accessory RF mounting plate
  - Accessory RF mounting bracket
  - Accessory clamp
  - Accessory clip pad
  - Accessory hook
  - Accessory clip pad and hook
  - Accessory pocket
  - Console light
  - Fan
36. InfoLink® Ready
37. InfoLink for Windows® Ready

### Operator Compartment

Soft, rounded surfaces make compartment interior more comfortable. Streamlined exterior smooths entry/exit for the operator. A low floor height, (9.4") (239 mm), first greets the operator. A 270 in<sup>2</sup> (1742 cm<sup>2</sup>) floor and patented suspended floorboard provide comfortable footing.

The brake pedal design allows variable side-stance positions for the operator. The operator can change positions to increase comfort and productivity.

Five-point positioning provides control and stability, starting with the right hand on the multi-task controller and the left hand on the steer tiller. Left foot on the brake pedal and the right foot on the presence sensor. The operator's back is naturally fitted against the wrap-around support cushion.

An entry bar with sensors to automatically slow truck travel, encourages safe foot positioning inside the truck.

The multi-task control enables the operator to maneuver the truck while blending lift and accessory functions for improved productivity. Control handle activation forces are reduced. The soft grip steer tiller with hydrostatic steering or optional electronic power steering reduces operator fatigue.

Operator visibility is improved with:

- Low profile power unit
- MonoLift® mast
- Angled overhead guard
- Variable side stance

Superior thermal management is the result of several design features: reduced heat generating components, positioning of heat generating components away from the compartment, padding to insulate the compartment from heat, and improved air paths through the truck.

Clipboard surface and console storage pockets are standard.

### Crown's Access 1 2 3® Comprehensive System Control

provides optimum performance and control by offering a communication interface for operators and technicians, intelligent coordination of lift truck systems and simplified service with advanced diagnostics.

The Crown display is used for easy trouble shooting, accessing service history and setting performance features. A distribution panel is conveniently located with all test points, control fuses and central wiring for easy troubleshooting.

Three modes of performance can be selected to accommodate operator experience or application requirements.

### OnTrac® Anti-Slip Traction Control

Crown's Access 1 2 3 technology monitors truck dynamics, optimizes traction, reduces spinning during acceleration, prevents lock-up during braking, and greatly extends tire life.

## RM 6000 Series RMD 6000 Series

## Technical Information

### Travel

Crown's AC traction system is a closed loop traction control system that maintains top speed throughout the battery charge. Engineered and manufactured by Crown, the AC motor, controller and drive unit are designed specifically for lift truck applications.

On an inclined surface or when interfacing with push-back racking, the "truck hold" feature electronically brakes the truck when the handle is in neutral. The operator does not have to release the brake pedal, improving comfort and control in these applications. Selected travel speed remains constant regardless of surfaces, load weight or grades. Less throttling of control handle means better truck control and less fatigue to the operator.

### Lift/Lower

The AC lift system boasts industry-leading lift and lower speeds. The Crown built motor and controller are dedicated and designed to improve the efficiencies of the lift-lower functions. The standard regenerative lowering puts energy back in the battery as the mast is lowered. Movement of the mast is smooth and controlled for increased operator productivity.

### Steering

Drive tire rotates 190° for maximum maneuverability. The electronic power steering uses an AC steer motor and steering control module integrated with the Access 1 2 3 System for fast, reliable steering response. The smooth, quiet steering requires minimal operator effort at the steer tiller.

### Braking

A disc brake on the motor armature shaft combined with motor regenerative braking provides sure braking with fewer parts and maintenance requirements. The offset, articulated drive-unit design improves drive tire brake force. Regenerative motor braking helps save energy, and decreases motor temperature.

### Suspension

The offset, articulated drive-unit design provides positive floor contact.

### Load Handling

The optional Load Handling Assist package provides rack height select and tilt position assist features. The Rack Height Select feature allows the truck to be programmed to stop at preselected heights. With one-touch of the multi-task trigger while lifting or lowering, the mast will stop at the next programmed height. Another useful option is the Tilt Position Assist. This allows the fork tilt to stop at a preprogrammed position for maximum fork clearance when entering pallets.

Also optional, the Capacity Monitor shows the approximate weight on the forks and the fork height. It will alert the operator when the truck capacity is exceeded for the fork height. It will also show how high or to which lift zone you can raise the load.

### Mast

The MonoLift® mast design with angled overhead guard improves visibility for high or low stacking. Crown's patented staging cushions coupled with lowering dampers and speed reductions at maximum lift improve overall load handling control. Elevated load sway and side bowing are minimized through the use of a closed cross-section mast construction. Rolled "I-beams" continuously welded to a formed plate create a full length, deep cross-section mast capable of resisting front and side loading equally well. Lift cylinders, hoses, cable and chain within the mast are protected from the operating environment, but are readily accessible for service. Built-in sensors detect chain slack and shut down lower functions.

### Xpress™ Lower

The optional Xpress Lower feature dramatically increases lower speeds allowing you to reduce cycle times and increase productivity. Trucks equipped with Xpress Lower take advantage of three automatically controlled lower speed zones to ensure optimum performance and safety.

### Reach Mechanism

The cast reach carriage is sculpted to allow for excellent visibility to the load and forks. A soft start/stop of the reach mechanism is critical to operator confidence and load stability. A sensor recognizes when the reach and retract functions are starting or stopping and adjusts the speed accordingly.

### Carriage

A hook-type carriage conforming to ITA specifications is used. Load backrest is standard.

### Warning Device Options

Audible or Visual Alerts

Safety considerations and dangers associated with audible travel alarms and lights include:

- Multiple alarms and/or lights can cause confusion.
- Workers ignore the alarms and/or lights after day-in and day-out exposure.
- Operator may transfer the responsibility for "looking out" to the pedestrians.
- Annoys operators and pedestrians.

### Other Options Available

Contact factory for additional options.

*Dimensions and performance data given may vary due to manufacturing tolerances. Performance is based on an average size vehicle and is affected by weight, condition of truck, how it is equipped and the conditions of the operating area. Crown products and specifications are subject to change without notice.*



### Crown Equipment Corporation

New Bremen, Ohio 45869 USA

Tel 419-629-2311

Fax 419-629-3796

crown.com

You can count on Crown to build lift trucks designed for safe operation, but that's only part of the safety equation. Crown encourages safe operating practices through ongoing operator training, safety-focused supervision, maintenance and a safe working environment. Go to [crown.com](http://crown.com) and view our safety section to learn more.

Because Crown is continually improving its products, specifications are subject to change without notice.

Crown, the Crown logo, the color beige, the Momentum mark, Access 1 2 3, InfoLink, MonoLift, OnTrac, Work Assist, InfoPoint, Xpress Lower and ThermoAssist are trademarks of Crown Equipment Corporation. Other trademarks are property of their owners.

Copyright 2011-2017 Crown Equipment Corporation  
SF18535 Rev. 05-17  
Printed in U.S.A.